



UNIVERSITY OF CAMBRIDGE INTERNATIONAL EXAMINATIONS  
International General Certificate of Secondary Education

CANDIDATE  
NAME

CENTRE  
NUMBER

--	--	--	--	--

CANDIDATE  
NUMBER

--	--	--	--	--



**DESIGN AND TECHNOLOGY**

**0445/33**

Paper 3 Resistant Materials

**May/June 2013**

**1 hour**

Candidates answer on the Question Paper.

No Additional Materials are required.

**To be taken together with Paper 1 in one session of 2 hours 15 minutes.**

**READ THESE INSTRUCTIONS FIRST**

Write your Centre number, candidate number and name on all the work you hand in.

Write in blue or black pen.

You may use a soft pencil for any diagrams, graphs or rough working.

Do not use staples, paper clips, highlighters, glue or correction fluid.

DO **NOT** WRITE IN ANY BARCODES.

**Section A**

Answer **all** questions in this section.

**Section B**

Answer **one** question in this section.

You may use a calculator.

The total of the marks for this paper is 50.

The number of marks is given in brackets [ ] at the end of each question or part question.

For Examiner's Use	
<b>Section A</b>	
<b>Section B</b>	
<b>Total</b>	

This document consists of **15** printed pages and **1** blank page.



**Section A**

Answer **all** questions in this section.

**1** State **three** items of information needed when ordering screws.

- 1 .....
- 2 .....
- 3 ..... [3]

**2** Complete the table below by naming each tool and giving a specific use.

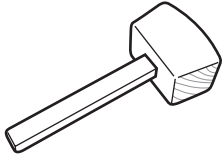
Tool	Name	Specific use
		
		

[4]

**3** Fig. 1 shows a 5 mm thick piece of mild steel marked out ready to be drilled.

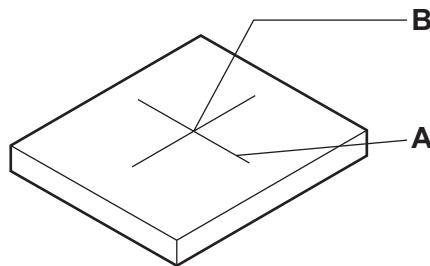

**Fig. 1**

Name a tool used to:

**(a)** mark line **A**;

..... [1]

**(b)** make an indentation at centre **B** ready for drilling.

..... [1]

4 Fig. 2 shows two identical size pieces of solid wood used for a shelf.

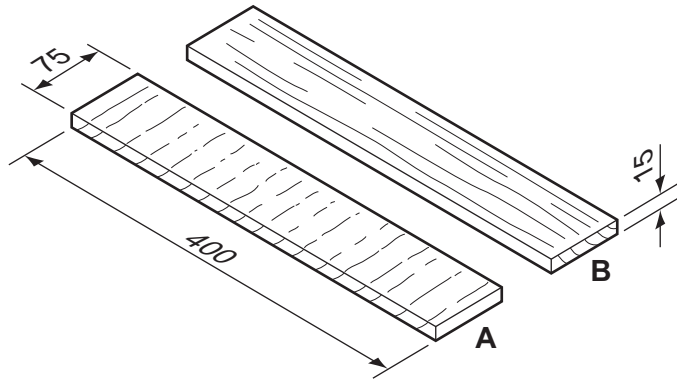

Fig. 2

(a) State which of the two pieces of solid wood is the stronger, A or B.

..... [1]

(b) Give a reason for your choice.

..... [1]

5 Fig. 3 shows a bookcase and a table.

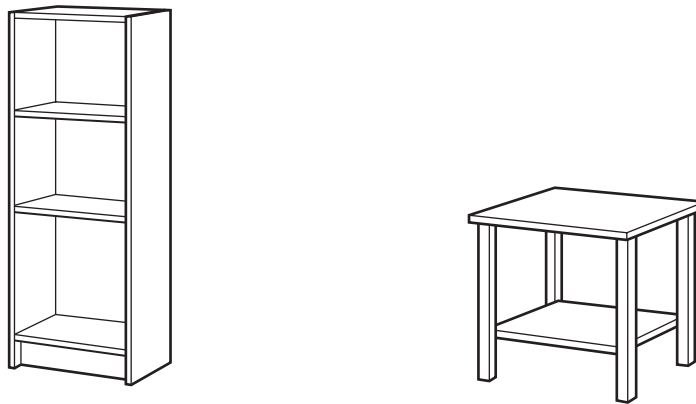

Fig. 3

Complete the sentences by giving the correct type of construction from the list.

**laminated**                      **frame**                      **carcase**                      **shell**                      **stool**

(a) The bookcase is an example of ..... construction. [1]

(b) The table is an example of ..... construction. [1]

6 Describe **one** situation where a marking knife, rather than a pencil, would be used to mark a line on wood.

..... [1]

7 Fig. 4 shows two garden chairs.

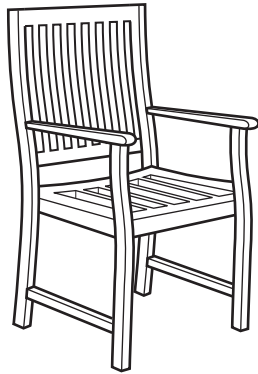

hardwood chair



plastic chair

**Fig. 4**

Explain why the hardwood chair could be more expensive to manufacture in quantity than the chair made from plastic.

.....  
.....  
..... [2]

8 Fig. 5 shows two items of equipment used with a centre lathe.

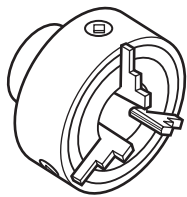

**A**

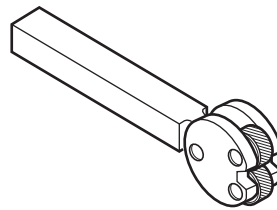

**B**

**Fig. 5**

Name each item of equipment.

**A** .....

**B** ..... [2]

9 Fig. 6 shows a plastic kettle.



Fig. 6

Describe **three** ways in which the designer has considered the user in the design of the plastic kettle.

- 1 .....
- 2 .....
- 3 ..... [3]

10 Fig. 7 shows a kitchen utensil.

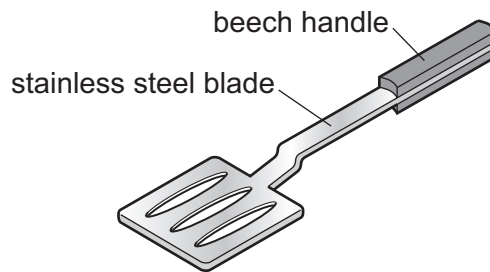

Fig. 7

(a) Give **one** benefit of using:

- (i) beech for the handle;  
..... [1]

- (ii) stainless steel for the blade.  
..... [1]

(b) State **two** methods of attaching the beech handle permanently to the stainless steel blade.

- 1 .....
- 2 ..... [2]

Section B

Answer **one** question in this section.

11 Fig. 8 shows a mobile phone holder made from acrylic.

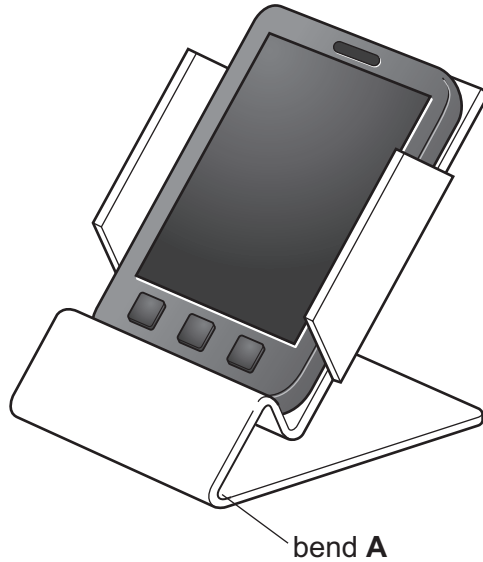

Fig. 8

(a) Give **two** reasons why acrylic is a suitable material for the mobile phone holder.

1 .....

2 ..... [2]

(b) When working with acrylic the surfaces can scratch easily.  
Give **one** way of protecting the surfaces of acrylic from scratches.

..... [1]

(c) (i) An incomplete development (net) of the mobile phone holder is shown below.  
Complete the development (net) by adding the bend lines and the cut lines.

cut lines ——— bend lines - - - - -



[5]

(ii) Explain why a marker pen, rather than a scribe, would be used to mark out the development (net).

.....  
.....  
..... [2]

(d) (i) Name **two** saws that could be used to cut out the development (net).

1 .....  
2 ..... [2]

(ii) When drilling acrylic there is a danger that the acrylic could crack.  
Give **two** precautions you could take to prevent the acrylic from cracking.

1 .....  
2 ..... [2]

(e) Give **two** benefits of making a card model of the mobile phone holder before making it from acrylic.

1 .....  
2 ..... [2]

(f) Describe how the edges of the acrylic could be finished to a high quality.

.....  
.....  
.....  
.....  
..... [4]

(g) Use sketches and notes to show how you would produce bend **A** in Fig. 8.

*For  
Examiner's  
Use*

[5]



12 Fig. 9 shows an incomplete design for a wall-mounted towel holder. The towel holder has a hardwood back and aluminium rails.

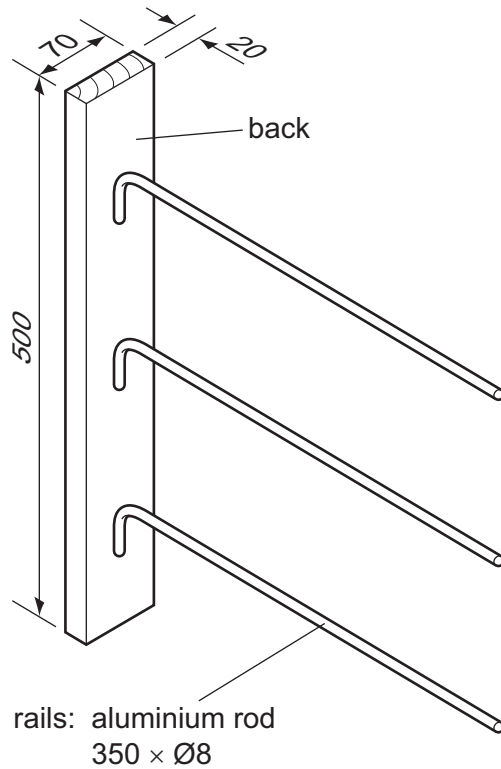

Fig. 9

(a) Give **two** reasons why hardwood is suitable for the back.

- 1 .....
- 2 ..... [2]

(b) State **two** properties of aluminium that make it suitable for the rails.

- 1 .....
- 2 ..... [2]

(c) State a suitable clear finish for the hardwood back.

- ..... [1]

(d) Fig. 10 shows a length of hardwood from which the back of the towel holder will be cut.

For  
Examiner's  
Use

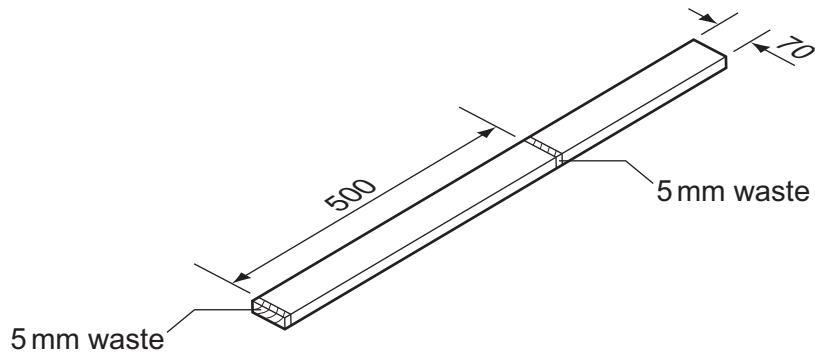

Fig. 10

(i) Name an appropriate saw that could be used to cut the hardwood to length.

..... [1]

(ii) Use sketches and notes to show how the length of hardwood would be held securely while the hardwood is sawn to length.

[3]

(e) Fig. 11 shows one end of the back of the towel holder after it has been sawn to length.

For  
Examiner's  
Use

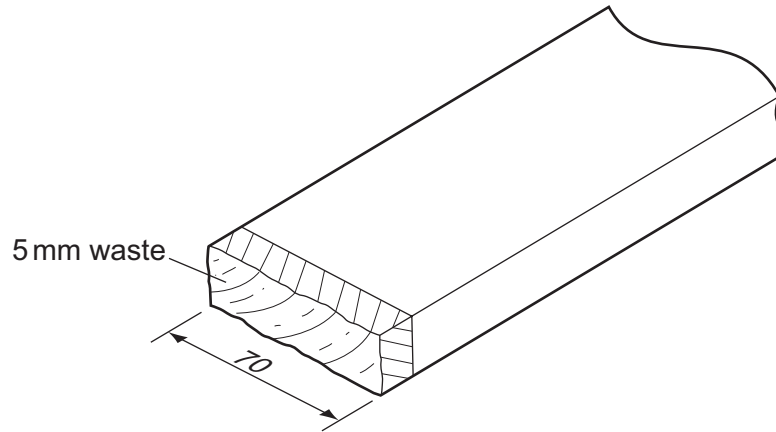

Fig. 11

Use sketches and notes to show how the 5 mm waste could be removed using:

(i) a sanding disc;

[3]

(ii) a jack plane.

[3]

- (f) Fig. 12 shows details of the bend in a rail.

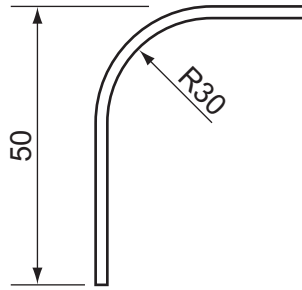
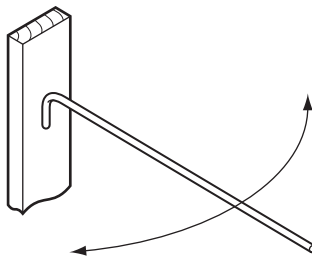

Fig. 12

Use sketches and notes to show a bending jig that could be used to form the bend at the end of the rail.

[4]

- (g) Use sketches and notes to show how **one** rail could be attached to the back and allowed to move as shown below. Include details of materials, fittings and fixings used.



[6]

13 Fig. 13 shows views of an incomplete design for a drawing equipment case and drawing board.

The case and drawing board are made from 15 mm thick manufactured board.

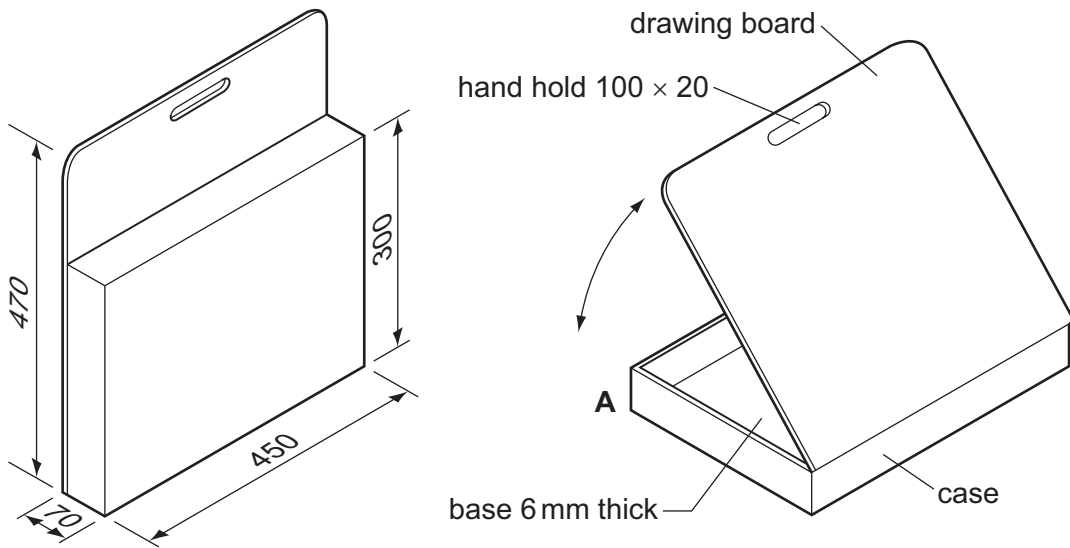

Fig. 13

(a) State **two** items of research the designer would need to consider when designing the drawing equipment case and drawing board.

1 .....

2 ..... [2]

(b) Sketch and name a single hinge that could be used to join the drawing board to the case.

Name of hinge ..... [3]

(c) Sketch and name a suitable joint that could be used at corner **A**.

Name of joint ..... [4]

- (d) Use sketches and notes to show how a 6 mm thick base could be fitted to the case. The edge of the base must not be visible.

[3]

- (e) Use sketches and notes to show how the drawing board could be secured to the case when carried.

[3]

- (f) Describe the stages involved in cutting out the hand hold in the drawing board. Do not include details of marking out.

.....

.....

.....

.....

.....

.....

.....

.....

.....

.....

[4]

- (g) The drawing board needs to be used at three different angles:  $30^\circ$ ,  $45^\circ$  and  $60^\circ$ .  
Use sketches and notes to show how the drawing board could be held in each of the three positions.  
Include details of materials, fittings and fixings used.

*For  
Examiner's  
Use*

[6]

**BLANK PAGE**

---

Permission to reproduce items where third-party owned material protected by copyright is included has been sought and cleared where possible. Every reasonable effort has been made by the publisher (UCLES) to trace copyright holders, but if any items requiring clearance have unwittingly been included the publisher will be pleased to make amends at the earliest possible opportunity.

University of Cambridge International Examinations is part of the Cambridge Assessment Group. Cambridge Assessment is the brand name of University of Cambridge Local Examinations Syndicate (UCLES), which is itself a department of the University of Cambridge.